

High speed forming, cutting and wrapping machine for products in different wrapping styles

U1-I



Products

- Hard and Soft Caramels
- Toffees
- Chewy Sweets
- Chewing Gum

Output

- up to 1000 products/min

Product dimensions



Double Twist/
Bottom Fold:
Length: 16–45 mm
Width: 12–25 mm
Height: 4–15 mm
Ø: 8,8–15 mm
Side Fold:
Length: 25–45 mm
Width: 8–25 mm
Height: 5–15 mm
Special sizes upon
request



U1-I

Wrapping material

- Wax paper
- Cellophane
- Aluminium/paper – coated

Material dimensions

- Reel diameter: up to 350 mm
- Core diameter: 70–76,2 mm

Utilities

- Connected load: 12 kVA
- Compressed air consumption: 1,5 m³/h; 600 kPa
- Cooling water consumption: 0,15 m³/h
- Temperature: 10 ... 15°C
- Pressure: min. 200 kPa

Measurements

- Machine:
 - Length: 1860 mm
 - Width: 1500 mm
 - Height: 1975 mm
- Switch cabinet:
 - Length: 1200 mm
 - Width: 500 mm
 - Height: 2000 mm

Weight

- Machine: 2100 kg
- Switch cabinet: 270 kg

Combination

Depending on the product, the machine can be synchronized either with a batch roller and rope sizing machine (toffees, hard and soft caramels) or an appropriate extruder and cooling tunnel (chewing gum, bubble-gum, chewy candy).

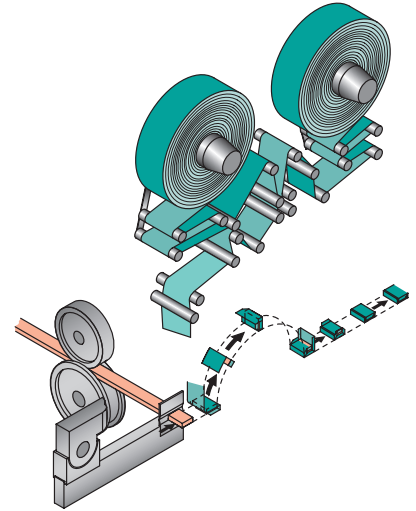
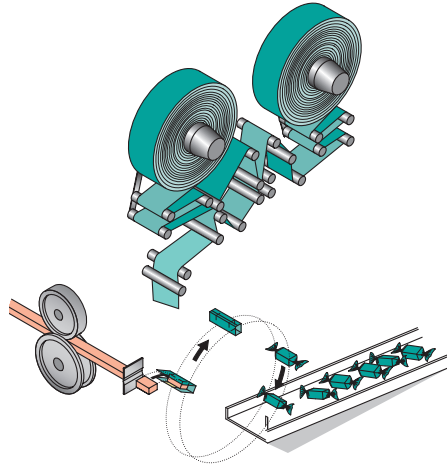

Special features

- prefeeder and water-cooled guillotine knife
- Automatic splicer to change wrapping material reels without stopping the machine
- Servo control with PLC functions
- Central lubrication of all gear parts including oil pressure control/temperature control
- Pneumatic core locking and reel tensioning devices
- Servo-driven wrapping material feed rollers and wrapping material knife
- All electrical and electronic components are located in a separate switch cabinet
- Excellent accessibility for operation, maintenance and cleaning purposes
- Easy operation due to the touch screen

- Due to the automatic operation, several machines can be handled by one operator
- System of protection: IP 54

Options

- Electronic speed control
- Photo-electric print registration
- Additional reel holders for a second wrapping material (under strip) with automatic splicer for outer wrapping material
- sealing unit for the longitudinal seam and cooling section
- Ejecting unit for unwrapped products